

E. CHILDS.  
CUTTING-OFF ATTACHMENT FOR LATHES.

No. 550,440.

Patented Nov. 26, 1895.

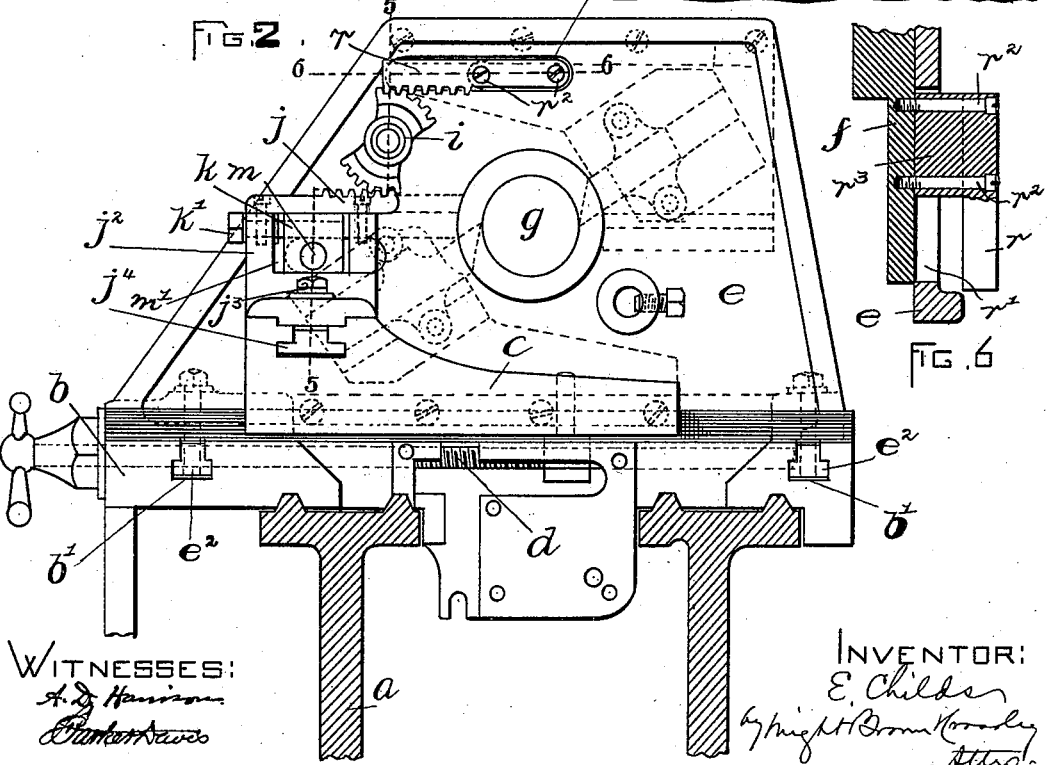
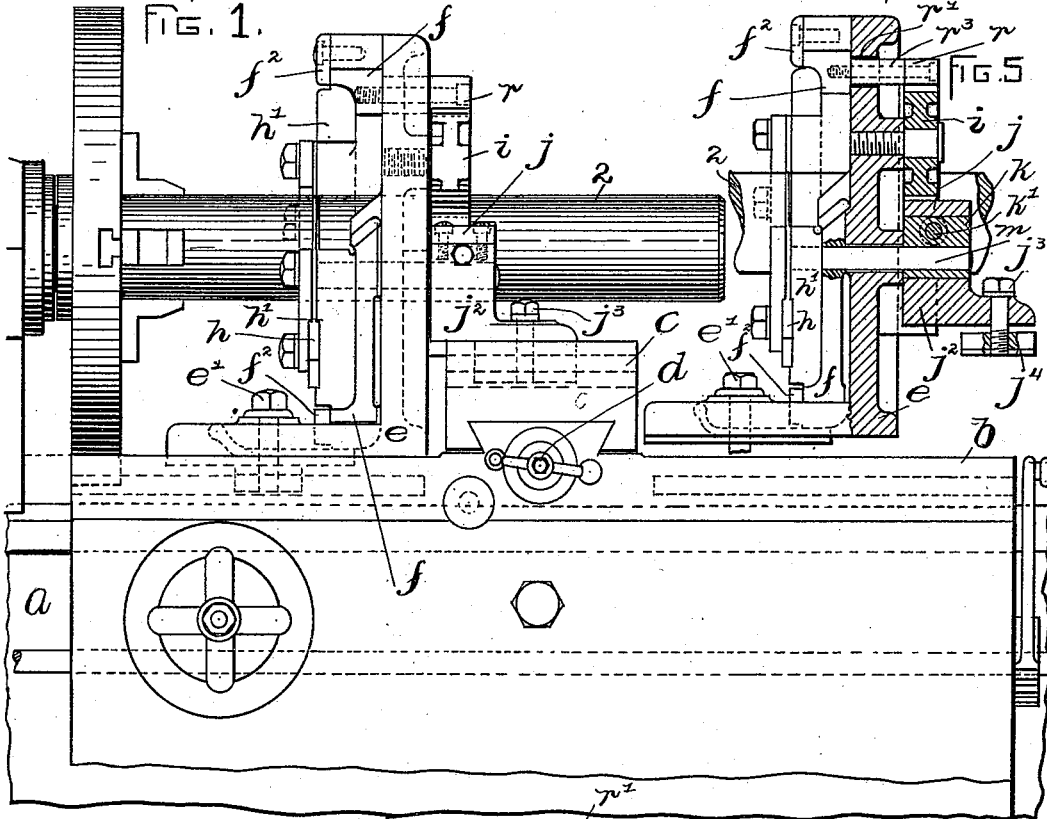

WITNESSES:  
*A. J. Harrison*  
*Charles Davis*

INVENTOR:  
*E. Childs*  
 by *Wm. H. Brown* Counselor  
*Atty.*

(No Model.)

2 Sheets—Sheet 2.

E. CHILDS.

CUTTING-OFF ATTACHMENT FOR LATHES.

No. 550,440.

Patented Nov. 26, 1895.

FIG. 4.

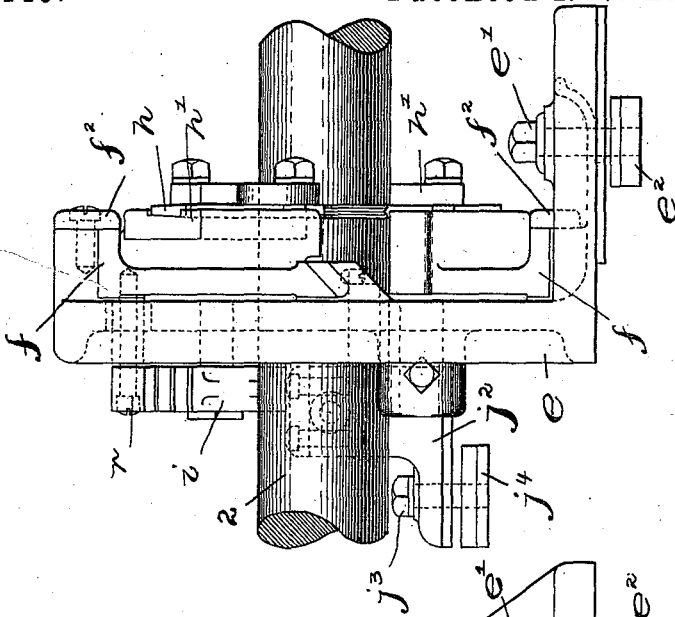
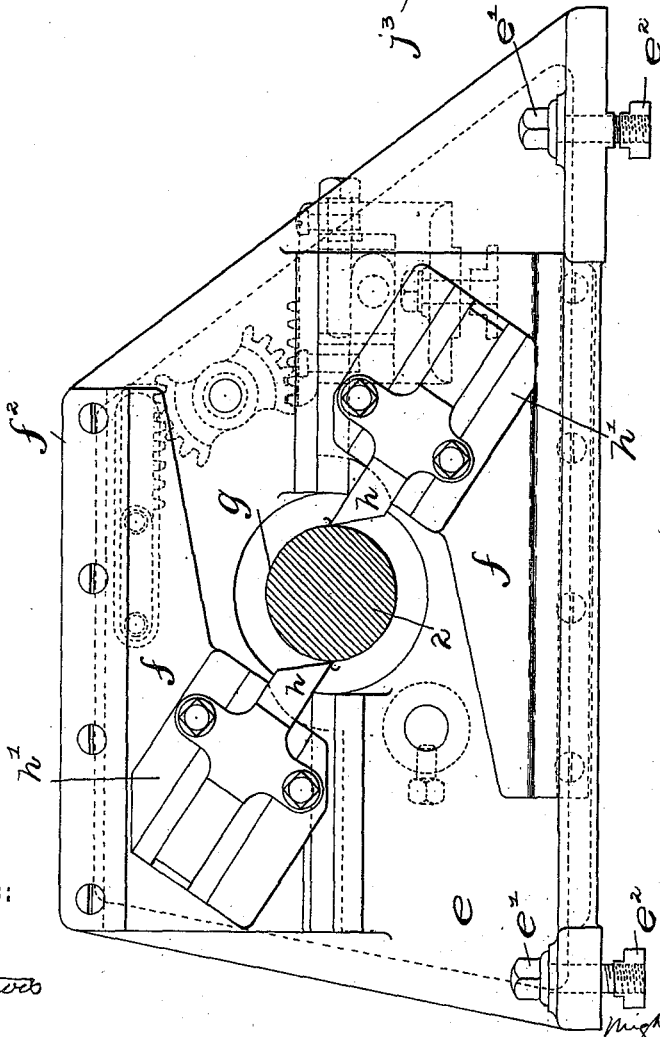

FIG. 3.



WITNESSES:

*A. S. Hanson*  
*Barthelme*

INVENTOR:  
*E. Childs*

*Wight Brown Comley*

# UNITED STATES PATENT OFFICE.

EUGENE CHILDS, OF DOVER, NEW HAMPSHIRE, ASSIGNOR TO THE AUTOMATIC RAPID LATHE COMPANY, OF BOSTON, MASSACHUSETTS.

## CUTTING-OFF ATTACHMENT FOR LATHES.

SPECIFICATION forming part of Letters Patent No. 550,440, dated November 26, 1895.

Application filed September 19, 1893. Serial No. 485,782. (No model.)

To all whom it may concern:

Be it known that I, EUGENE CHILDS, of Dover, in the county of Strafford and State of New Hampshire, have invented certain new and useful Improvements in Cutting-Off Attachments for Lathes, of which the following is a specification.

The present invention relates to a cutting-off attachment for lathes such as that shown and described in an application for Letters Patent of the United States filed by me August 21, 1893, Serial No. 483,653, and the principal object is to provide an attachment which can be readily applied, so that the tools will be fed by the cross-feed screw of the lathe and thus be capable of all the degrees of movement of said screw.

The invention has in view other objects, which will hereinafter appear.

The invention is illustrated in the accompanying drawings, of which—

Figure 1 shows a side elevation of a portion of a lathe with my cutting-off attachment applied thereto. Fig. 2 shows an elevation of the parts appearing in Fig. 1 with the lathebed in cross-section. Fig. 3 shows a side elevation of the cut-off attachment, looking toward the opposite side from that seen in Fig. 2. Fig. 4 shows an end elevation as viewed from the left of Fig. 2. Fig. 5 shows a section on line 5 5 of Fig. 2. Fig. 6 shows a section on line 6 6 of Fig. 2.

The same letters and numerals of reference indicate the same parts in all the views.

In the drawings, the letter *a* designates the lathe-bed; *b*, the longitudinally-movable carriage; *c*, the cross-feed tool-carriage, and *d* the cross-feed screw. The carriage *b* has longitudinal T-shaped slots *b'* in its top.

The cutting-off attachment is constructed and applied as follows: A supporting-frame *e* is constructed and arranged to stand crosswise on the carriage *b*, close up against the cross-feed tool-carriage *c*, with its central circular opening *g* in alignment with the center line of the lathe, so that the work 2 can pass through it. Said supporting-frame is rigidly secured to the carriage *b* by bolts *e'* and shouldered nuts *e''* engaging the T-shaped slots *b'* in said carriage. Said frame *e* is formed

with slideways which receive and support two tool-slides *f*, gibs *f''* confining the said slides in the ways. The cutting-tools *h* are set at an angle to the plane of movement in holders *h'*, fastened to the slides *f*, so that the forward longitudinal cutting side of each tool is parallel with a radial line of the work. Set in this way the cutting action of the tools is considerably increased, a shearing effect being produced. The upper tool-slide carries a short rack *r* on the opposite side of the frame and connected with the slide through a slot *r'* in the frame by means of screws *r''*, a block *r'''* being interposed between the rack and slide. A double-ended segment *i* is supported on a stud fastened in the frame and meshes with the rack *r*. Said segment also meshes with a short rack *j*, fastened to a block *j''*, which stands out at one side of the frame and is adapted to rest upon the cross-feed tool-carriage and be rigidly connected therewith by a bolt *j'''* and a shouldered nut *j''''*, engaging the T-shaped slot of the said carriage, which the tool-post ordinarily engages and from which said tool-post has been removed.

The block *j''* is connected with the lower tool-slide through the following means: Said block is formed with a recess *m'*, whose cover is the rack *j*, and a block *k* occupies said recess and is adjustable therein by means of a screw *k'* and is connected with the tool-slide by a pin *m* extending through a slot in the carriage. By turning the screw *k* the lower tool can be adjusted independently of the upper one.

The operation of the device will be apparent. The block *j''* receives its motion directly from the cross-feed screw and transmits it to the lower tool-slide, and through the rack *j*, segment *i*, and rack *r* motion is imparted to the upper tool-slide.

It will be observed that my invention provides a cutting-off device which can be easily and quickly attached to the lathe and has all the advantages of the regular cutting-off machine in the matter of automatic variable speed. By making one tool adjustable independently of the other I provide for the nice adjustment necessary to make each tool per-

form its proper proportion of work. The tools are first set roughly by a gage and then adjusted by the screw *k*.

The attachment provides a device by which long screws may be cut very rapidly. A ring is placed in the central opening and constitutes a following rest always near the tools, and the latter are set to clear each other and by their shearing action will rapidly cut the thread.

Having thus described my invention, what I claim as new, and desire to secure by Letters Patent, is—

1. A cutting off attachment for lathes comprising in its construction a supporting frame adapted to stand crosswise on the longitudinally movable carriage of the lathe, means for fixedly attaching said frame to said carriage, a tool-slide on the frame and means for fixedly attaching said tool-slide to the cross-feed tool carriage of the lathe.

2. A cutting off attachment for lathes comprising in its construction a supporting frame adapted to stand crosswise on the longitudinally movable carriage of the lathe, means for fixedly attaching said frame to said carriage, tool slides on the frame, suitable connections between said tool-slides and means for fixedly connecting one of said slides with the cross-feed tool carriage of the lathe.

3. A cutting off attachment for lathes comprising in its construction a supporting frame adapted to stand crosswise on the longitudinally movable carriage of the lathe, means for fixedly attaching said frame to said carriage, a tool-slide on the frame, a sliding block connected with said tool-slide and adapted to rest on the cross-feed tool carriage of the lathe, and means for fixedly attaching said block to said carriage.

4. A cutting-off attachment for lathes, comprising in its construction a frame adapted

to stand crosswise on the longitudinally-movable carriage of a lathe and having means for rigid attachment thereto, a sliding block supported at one side of said frame and adapted to rest on the cross-feed tool-carriage and having means for rigid connection therewith, and tool-slides on the frame and suitably connected together, one of said slides being connected with the said block.

5. A cutting-off attachment for lathes, comprising in its construction a frame adapted to stand crosswise on the longitudinally-movable carriage of a lathe and having means for attachment thereto, a block supported at one side of said frame and adapted to rest on the cross-feed tool-carriage and having means for connection therewith, tool-slides on the frame and suitably connected together, one of said slides being connected with the said block, and means for adjusting one tool-slide independently of the other.

6. A cutting-off attachment for lathes, comprising in its construction a frame adapted to stand crosswise on the longitudinally-movable carriage of a lathe and having means for attachment thereto, a block supported at one side of said frame and adapted to rest on the cross-feed tool-carriage and having means for connection therewith, an adjustable block in a recess in the first-named block, and tool-slides suitably connected together, one of them being connected with the adjustable block.

In testimony whereof I have signed my name to this specification, in the presence of two subscribing witnesses, this 6th day of September, A. D. 1893.

EUGENE CHILDS.

Witnesses:

FRANK F. FERNALD,  
A. G. WHITTEMORE.